

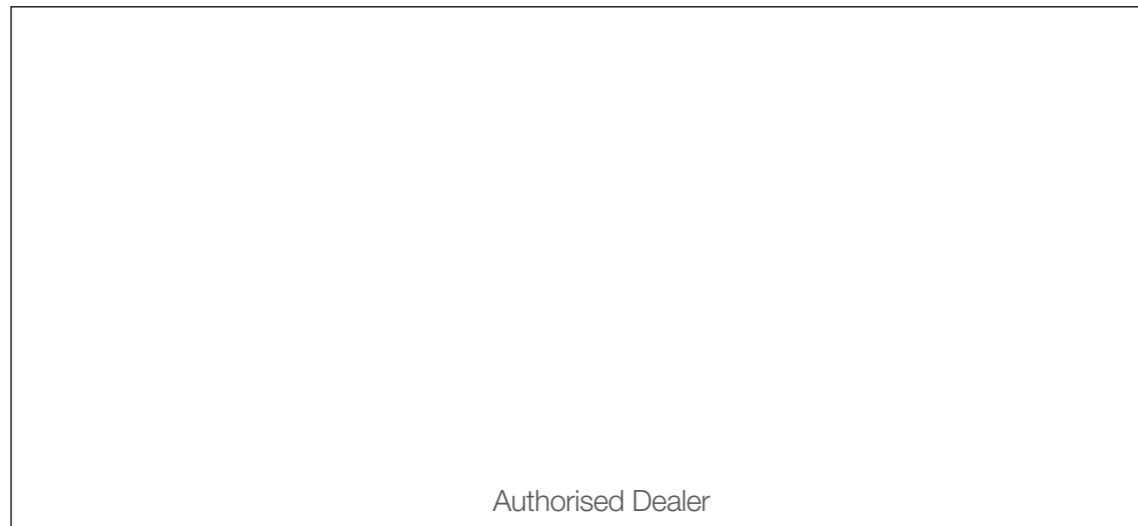

**2017/2018**



Global website : [aircon.panasonic.com](http://aircon.panasonic.com)



Authorised Dealer



Do not add or replace refrigerant other than the specified type.  
Manufacturer is not responsible for the damage and deterioration in safety due to usage of other refrigerant.

• Specifications are subject to change without prior notice for further improvement • The contents of this catalogue are effective as of April 2017  
• Due to printing considerations, the actual colours may vary slightly from those shown • All graphics are provided merely for the purpose of illustrating a point

**NEW**



# FSV-EX Advantages



The most efficient, powerful and quiet system in Panasonic's history. There has never been a VRF system like it. It's the story of a true game changer.

## Extraordinary energy-saving performance

The FSV-EX marks a revolutionary step forward in VRF efficiency. A look at the incredible EER value clearly indicates that. What's more, this high EER value is achieved even during part load operation. This shows the extraordinary energy-saving performance the FSV-EX is capable of providing.

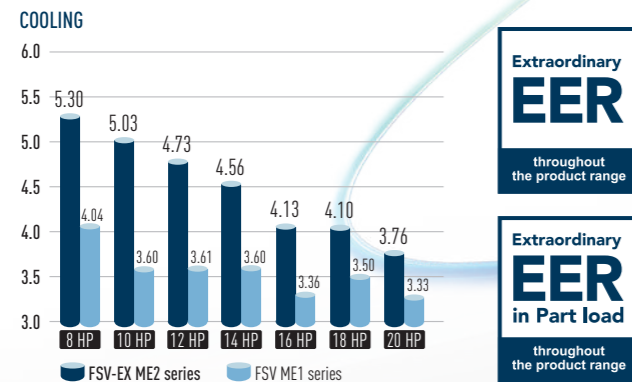

**Extraordinary EER**  
throughout the product range

**Extraordinary EER in Part load**  
throughout the product range



## Low-noise operation

Numerous technological innovations, including an improved compressor and a newly designed bell mouth and larger fan, have dramatically reduced the outdoor noise level. The result is an even more comfortable building environment.

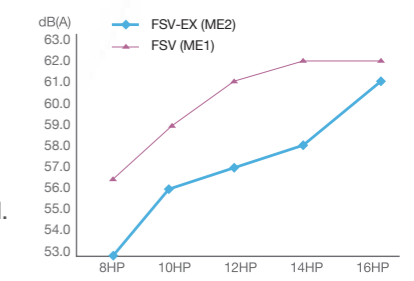

## Multiple large-capacity all inverter compressors (more than 14HP)

Two independently controlled inverter compressors achieve high efficiency. Redesigned components in the body provide performance improvement especially in the rated cooling condition and EER performance.



## Extended operation range up to 52°C

The FSV-EX can provide cooling even when the outside temperature reaches a maximum of about 52°C. And amazingly, it can still operate at 100% capacity when the outside temperature is as high as 43°C. This high power capability enables reliable operation even under extremely high temperature conditions.

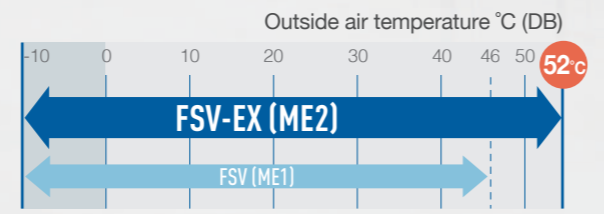

## Enlarged heat exchanger surface area with triple surface\*

The new heat exchanger features a triple-surface construction. Compared to the divided dual-surface construction in current models, there is no division of space and the area for heat exchange is larger. Also, highly efficient piping pattern increases heat exchange performance by 5%.

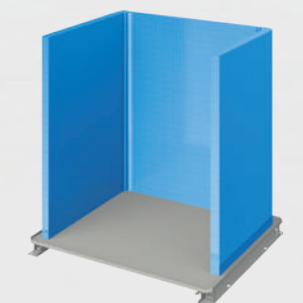

\* For 8 & 10HP unit, the heat exchanger is 2 row design.

# High-spec Wired Remote Controller

NEW

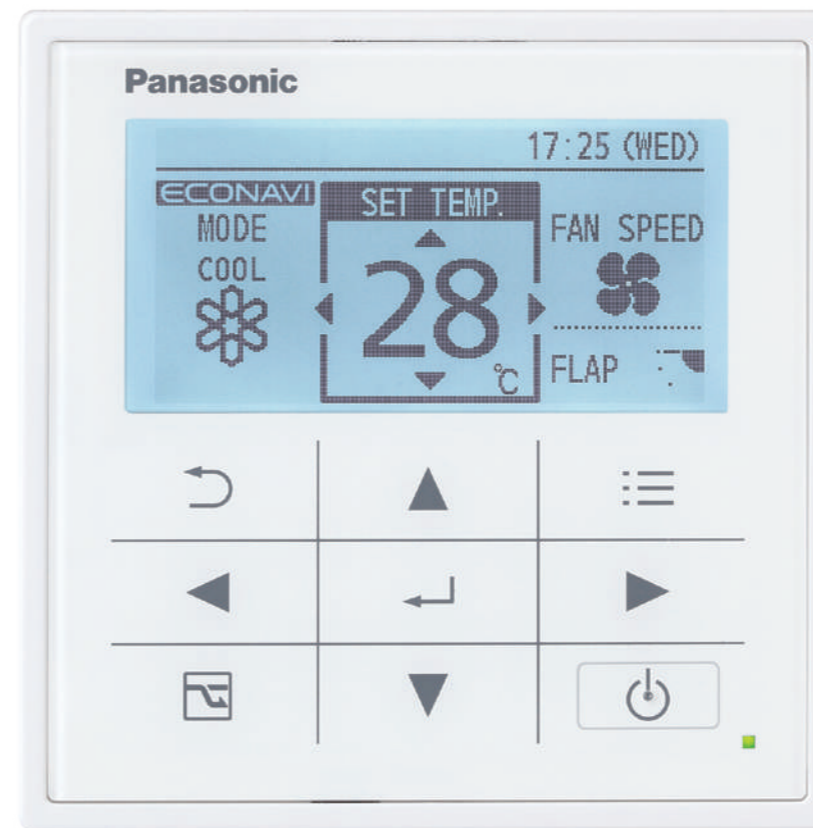

Large 3.5" full-dot LCD with white LED backlight

Characters and icons are clearly displayed for improved visibility. The display is also large enough to provide a wide range of information for easy confirmation of operation conditions.



Stylish, easy-to-use touch key design

The elegant, flat design features large touch keys in a simple layout enabling easy, intuitive operation.

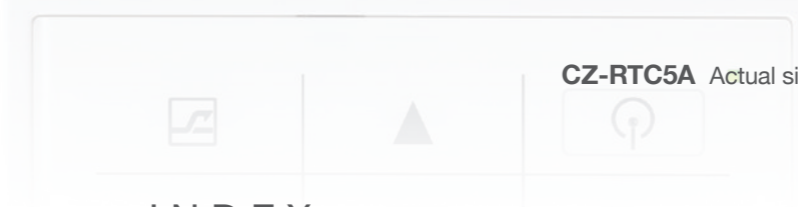

CZ-RTC5A Actual size

## INDEX

2 FSV-EX Advantages	32 K2 Type / Wall Mounted
5 High-spec Wired Remote Controller	34 U2 Type / 4-Way Cassette
6 Air Handling Unit Kit	38 Y2 Type / 4-Way Mini Cassette
8 FSV Systems	39 L1 Type / 2-Way Cassette
10 2-WAY FSV-EX ME2 Series	40 D1 Type / 1-Way Cassette
14 2-WAY Mini-FSV LE Series	41 T2 Type / Ceiling Mounted
20 Indoor Units	42 P1 Type / Floor Standing
22 FSV Indoor Units Range	43 R1 Type / Concealed Floor Standing
24 F2 Type / Mid Static Ducted	44 VRF Smart Connectivity
26 M1 Type / Slim Low Static Ducted	50 Panasonic AC Smart Cloud
27 Z1 Type / Slim Low Static Ducted Twenty Series	52 FSV Controllers
28 E2 Type / High Static Ducted	54 P-AIMS
29 E2 Type / Energy Saving High Fresh Air Ducted	55 Intelligent Controller
30 E1 Type / High Static Ducted	56 Panasonic VRF Global Project References
31 H1 Type / High-Fresh Air Ducted	

# FSV-EX Advantages

## Increased piping length for greater design flexibility

Adaptable to various building types and sizes  
Actual piping length : 200m  
Max piping length : 1,000m

\*1: 40 m if the outdoor unit is below the indoor unit.  
Please consult with Panasonic Service center.

Max. total length:1,000m

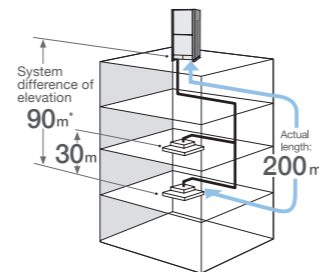

## Connectable indoor/outdoor unit capacity ratio up to 130% \*

FSV systems attain maximum indoor unit connection capacity of up to 130 %\* of the unit's connection range, depending on the outdoor and indoor models selected. So for a reasonable investment, FSV systems provide an ideal air conditioning solution for locations where full cooling/heating are not always required.

SYSTEM / HP	8	10	12	14	16	18	20	22	24	26	28	30	32	34	36	38	40	42	44	46	48	50	52	54	56	58	60	62	64	66	68	70	72	74	76	78	80		
MNcIU : 130%	13	16	19	23	26	29	33	36	40	43	46	50	53	56	59	63	64	64	64	64	64	64	64	64	64	64	64	64	64	64	64	64	64	64	64	64	64	64	64

MNcIU : Maximum Number of Connectable Indoor Unit

Note: If more than 100% indoor units are operated with a high load, the units may not perform at the rated capacity.  
For the details, please consult with an authorised Panasonic dealer

- \* If the following conditions are satisfied, the effective range is above 130 % up to 200 %.
- i ) Obey the limited number of connectable indoor units.
- ii ) The lower limit of operating range for heating outdoor temperature is limited to -10°CWB (standard -25°CWB).
- iii ) Simultaneous operation is limited to less than 130 % of connectable indoor units.

## Wide operating range

- Cooling operation is possible when outdoor temperature as low as -10°C DB
  - Cooling operation is possible when outdoor temperature as high as 52°C DB
  - Heating operation is possible when outdoor temperature as low as -25°C WB
- The remote controller temperature can be set from 18°C up to 30°C (Cooling), 16°C up to 30°C (Heating)\*.  
\* Depending on the type of remote controller.

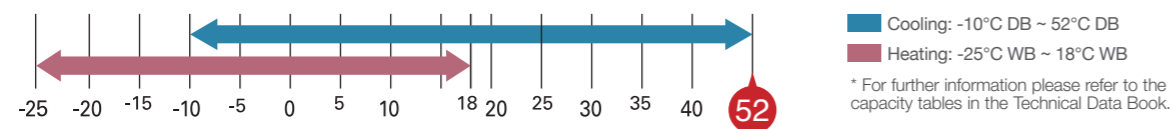

## Hi-durability outdoor unit

Corrosion-resistance treated for high resistance to rust and salty air to assure long-lasting performance.

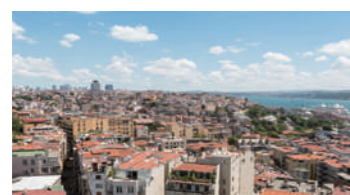

Note: Selecting this unit does not completely eliminate the possibility of rust developing.  
For details concerning unit installation and maintenance, please consult an authorised dealer.

\* Specific model with suffix "E" has this treatment.

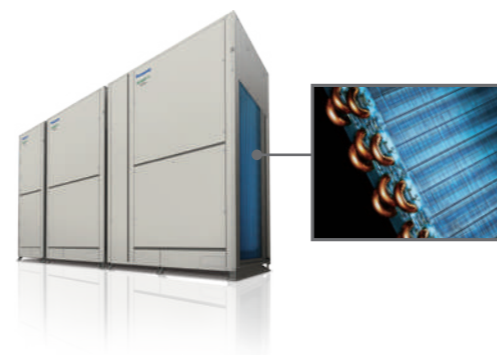

# FSV Systems

FSV systems are designed for energy savings, high efficiency, and high durability with strong cooling power even operating at high ambient temperature. Panasonic continuously apply advanced technologies to meet the requirements of diverse situations and contribute to the creation of comfortable living spaces.

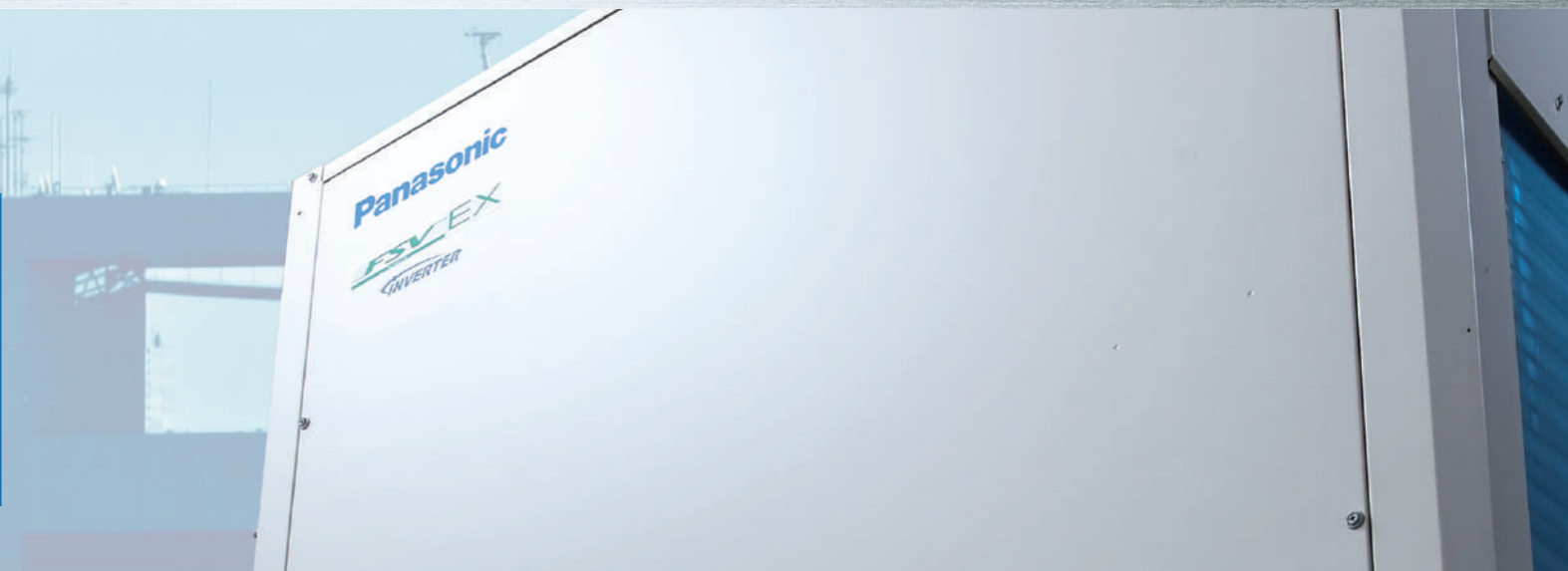

FSV EX ALL INVERTER

## 2-WAY FSV-EX ME2 Series

Extraordinary energy-saving performance and powerful operation

### Space-saving Combination Model

Cooling or Heating Type

New Hi-Durability Model

- Wide range of systems from 8HP to 80HP
- Class-leading EER of 5.3 (for 8HP model)
- Industry-leading low noise of 53.0 DB (8HP model)
- Cooling operation possible with outdoor temperature as high as 52°C (DB)
- Long maximum pipe length (up to 1,000 m)
- Up to 64 indoor units connectable
- External static pressure of 80 Pa
- Extended operating range allows heating with outdoor temperatures as low as -25°C (WB)
- Suitable for R22 refurbishing projects



### High Efficiency Combination Model

Cooling or Heating Type

New Hi-Durability Model

- Wide range of systems from 8HP to 64HP
- Class-leading EER of 5.3 (for 8HP model)
- Higher EER than the Space-saving Combination Model e.g., a combination of two 10HP units delivering 20HP reduces compressor load.



FSV EX INVERTER

## 2-WAY Mini-FSV LE2 Series NEW

For small-scale commercial and residential use

Cooling or Heating Type 1 phase

4/5/6 HP

- High external static pressure 35Pa
  - Wide operation range: Cooling: -10°C to 46°C DB, Heating at: -20°C to 18°C WB
  - Refrigerant chargeless up to 50m
  - Extraordinary energy saving: 5.08\* EER for 4HP model
  - Demand response (Peak cut) by optional parts.
  - Maximum number of connectable indoor units : 9\*
  - Diversity ratio 50-130%
  - DC inverter technology combined with R410A for excellent efficiency
  - Demand response (Peak cut) by optional parts.
  - One ampere starting current
  - Full range of indoor units and control options
  - Auto restart from outdoor unit
  - Hi-durability outdoor unit model is available.
  - Suitable for R22 renewal projects
- \* 6 HP only; 4 HP for 7 units, 5 HP for 8 units.



FSV EX INVERTER

## 2-WAY Mini-FSV LE1 Series

For small-scale commercial and residential use



Cooling or Heating Type 3-phase

8/10 HP

- High external static pressure 35Pa
- Wide operation range: Cooling: -10°C to 46°C DB, Heating at: -20°C to 18°C DB
- Maximum number of connectable indoor units : 13
- Diversity ratio 50-130%
- DC inverter technology combined with R410A for excellent efficiency
- Actual piping length: 150m (Total piping length: 300m)
- System difference of elevation: 50m / 40m (outdoor above/below)
- Difference in elevation between indoor units: 15m
- Demand response (Peak cut) by optional parts.
- One ampere starting current
- Full range of indoor units and control options
- Auto restart from outdoor unit
- Hi-durability outdoor unit model is available.
- Suitable for R22 renewal project



## 2-WAY FSV-EX ME2 Series

Appearance				
HP	22	44	66	
Model name	U-22ME2H7/U-22ME2H7E*	U-22ME2H7/U-22ME2H7E* U-22ME2H7/U-22ME2H7E*	U-22ME2H7/U-22ME2H7E* U-22ME2H7/U-22ME2H7E* U-22ME2H7/U-22ME2H7E*	
Power supply	380/400/415V/3-phase/50Hz			
Capacity	Cooling	kW 61.5 BTU/h 209,900	123.0 419,800	184.5 629,700
	Heating	kW 63.0 BTU/h 215,000	126.0 430,000	189.0 645,100
EER / COP	Cooling	W/W 3.60	3.60	3.60
	Heating	W/W 4.60	4.60	4.60
Dimensions	H x W x D	mm 1,842 x 1,540 x 1,000	1,842 x 3,140 x 1,000	1,842 x 4,740 x 1,000
Net weight	kg	375	750	1125
Electrical ratings	Cooling	Running current A 28.2 / 26.8 / 25.9 Power input kW 17.1	56.4 / 53.6 / 51.8 34.2	84.6 / 80.4 / 77.7 51.3
	Heating	Running current A 22.9 / 21.7 / 20.9 Power input kW 13.7	45.8 / 43.4 / 41.8 27.4	68.7 / 65.1 / 62.7 41.1
Starting current	A	2	4	6
Air flow rate	m³/h	24,300	48,600	72,900
	L/s	6,750	13,500	20,250
Refrigerant amount at shipment	kg	9.5	19.0	28.5
External static pressure	Pa	0 - 80	0 - 80	0 - 80
	Gas pipe mm (inches) Liquid pipe mm (inches) Balance pipe mm (inches)	Ø28.58 (Ø1-1/8) Ø15.88 (Ø5/8) Ø6.35 (Ø1/4)	Ø38.10 (Ø1-1/2) Ø19.05 (Ø3/4) Ø6.35 (Ø1/4)	Ø41.28 (Ø1-5/8) Ø19.05 (Ø3/4) Ø6.35 (Ø1/4)
Ambient temperature operating range	Cooling: -10°C (DB)~ +52°C (DB). Heating: -25°C (WB)~ +18°C (WB)			
Sound pressure level	Normal mode	dB (A) 60.0	63.0	65.0
	Silent mode (2)	dB (A) 55.0	58.0	60.0
Sound power level	Normal mode	dB 81.0	84.0	86.0

\* U-22ME2H7E is Hi-durability model.

### GLOBALREMARKS

Rated conditions:	Cooling	Heating
Indoor air temperature	27°C DB / 19°C WB	20°C DB
Outdoor air temperature	35°C DB	7°C DB / 6°C WB

These specifications are subject to change without notice.

### 22 HP

According to the installation site, you may choose the setting position in the depth direction of the anchor bolt from A, B or C.

A: (Installation hole pitch) For removing tube forward  
B: (Installation hole pitch) For removing the downward  
C: (Installation hole pitch)

### Top view

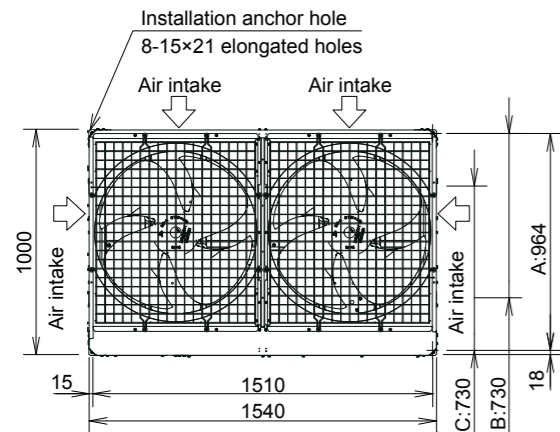

### Front view

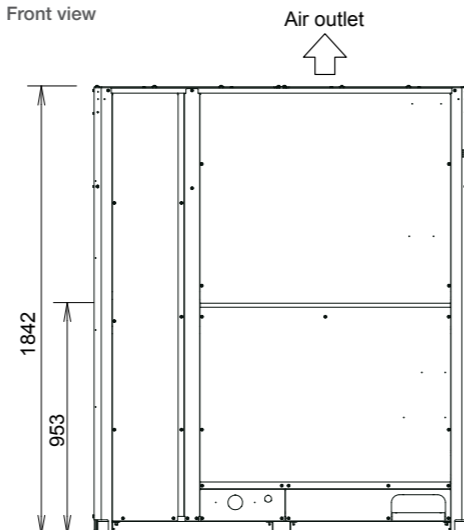

unit: mm

## Piping Design

Select installation locations so that the lengths and sizes of refrigerant piping are within the allowable ranges shown in the figure below.

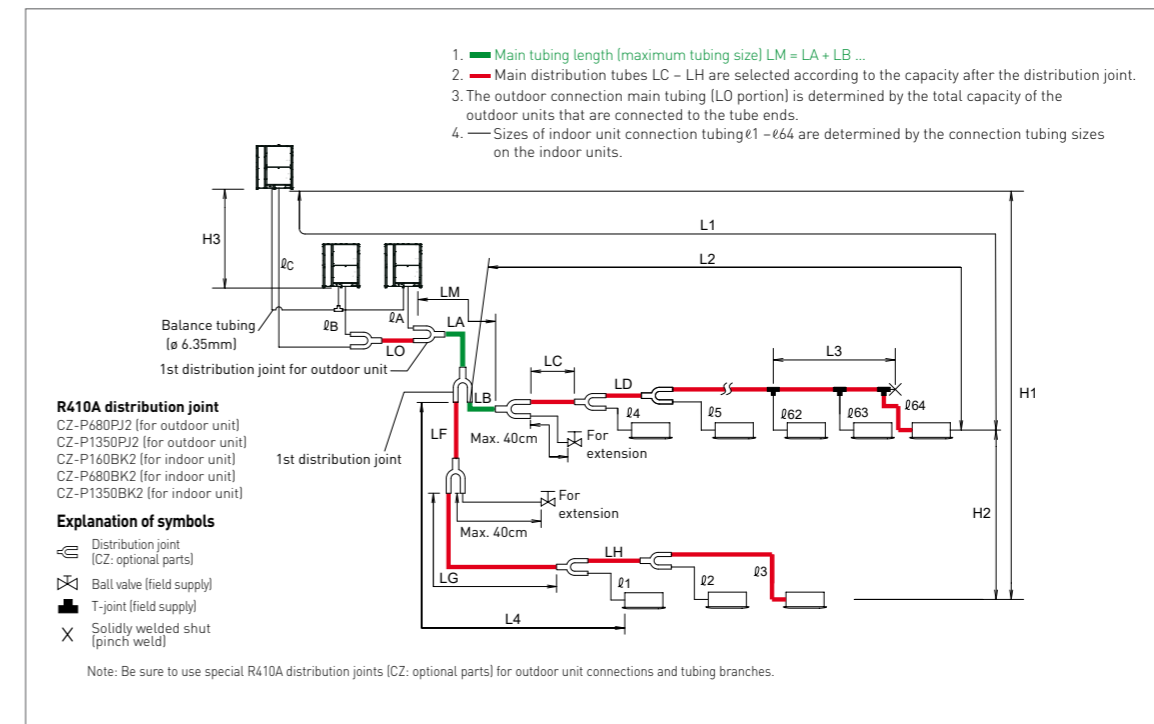

### Ranges that apply to refrigerant piping lengths and to differences in installation heights

Items	Mark	Contents	Length (m)
Allowable tubing length	L1	Max. tubing length	Actual length ≤200*2 Equivalent length ≤210*2
	Δ L (L2-L4)	Difference between max. length and min. length from the 1st distribution joint	≤50*5
	LM	Max. length of main tubing (at maximum size) * Even after 1st distribution joint, LM is allowed if at maximum tubing length.	— *3
	ℓ1, ℓ2~ ℓ64	Max. length of each distribution tube	≤50*7
Allowable elevation difference	L1+ ℓ1+ ℓ2~ ℓ63+ ℓA+ ℓB+LF+LG+LH	Total max. tubing length including length of each distribution tube (only liquid tubing)	≤1000
	ℓA, ℓB+LO, ℓC+LO	Maximum tubing length from outdoor's 1st distribution joint to each outdoor unit	≤10
	H1	When outdoor unit is installed higher than indoor unit	≤50
Allowable length of joint tubing	H2	When outdoor unit is installed lower than indoor unit	≤40
	H3	Max. difference between indoor units	≤15*6
Allowable length of joint tubing	L3	T-joint tubing (field-supply); Max. tubing length between the first T-joint and solidly welded-shut end point	≤2

L = Length, H = Height  
NOTE

- When checking the items 1-7 below, please confirm the detailed values (amount of additional refrigerant, connection limitations, piping specifications, etc.) listed in the installation manual prepared separately.
- The outdoor connection main tubing (LO portion) is determined by the total capacity of the outdoor units that are connected to the tube ends.
  - If the longest tubing length (L1) exceeds 90 m (equivalent length), increase the sizes of the main tubes (LM) by 1 rank for gas tubes and liquid tubes. Use a field supply reducer.
  - If the longest main tubing length (LM) exceeds 50 m, increase the main tubing size at the portion before 50 m by 1 rank for the gas tubes. Use a field supply reducer. Determine the length less than the limitation of allowable maximum tubing length.
  - If the size of the existing tubing is already larger than the standard tubing size, it is not necessary to further increase the size.  
\* If the existing tubing is used, and the amount of on-site refrigerant charge exceeds the value listed below, then change the size of the tubing to reduce the amount of refrigerant.  
Total amount of refrigerant for the system with 1 outdoor unit: 50 kg  
Total amount of refrigerant for the system with 2 outdoor units: 80 kg  
Total amount of refrigerant for the system with 3 outdoor units: 105 kg
  - When the tubing length exceeds 40 m, increase a longer liquid or gas tubing by 1 rank. Refer to the Technical Data for the details.
  - If the total distribution tubing length exceeds 500m, maximum allowable elevation difference (H2) between the indoor units is calculated by the following formula. Make sure the indoor unit's actual elevation difference should fall within the figure calculated as follows.  
Unit of account (meter):  $15 \times (2 - \text{total tubing length(m)} \div 500)$
  - If any of the tubing length exceeds 30m, increase the size of the liquid and gas tubes by 1 rank.



# Indoor Units

Wide choice of models depending on the indoor requirements

## Key Indoor Units Equipped DC motors



### ECONAVI sensor



Providing outstanding energy-saving performance, Panasonic's inverter VRF System can be connected to ECONAVI to detect when energy is being wasted. ECONAVI senses the presence or absence of people and the level of activity in each area of an office. When unnecessary heating or cooling is detected, indoor units are individually controlled to match office conditions for energy-saving operation.



ECONAVI Sensor CZ-CENSC1

#### Detection of the level of activity enables optimum power saving

Activity or absence of people at their desks and the level of activity in the office are detected in real time. Cooling or heating is automatically adjusted for optimum operation required to lower power consumption.

#### Sensor is remotely located to maximize the energy saving effect

Pillars, walls, cabinets and other fittings obstruct the sensors, reducing the area of detection and lowering the energy-saving effect. Taking into consideration blind spots, Panasonic enables the optimum layout for sensors in any office.

### NEW High-spec wired remote controller



#### Large 3.5" full-dot LCD with white LED backlight

Characters and icons are clearly displayed for improved visibility. The display is also large enough to provide a wide range of information for easy confirmation of operation conditions.

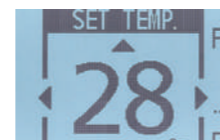

#### Stylish, easy-to-use touch key design

The elegant, flat design features large touch keys in a simple layout enabling easy, intuitive operation.



### All ducted series / F2,M1,Z1,E2,E1,H1, type

#### Discharge air temperature control

Smart sensors control discharge air temperature for precise room temperature control. Possible to reduce cold drafts during heating operation.

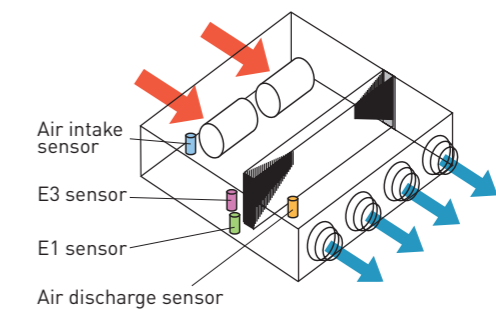

### Wall mounted / K2 type



Compact design with flat surface enables seamless match with any type of room interior

#### Noise reducing external valve kit

To reduce noise level of expansion valve. (Optional accessory)

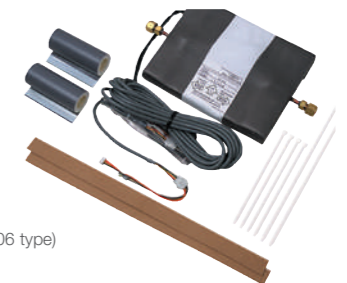

CZ-P56SVK2 (for 22 - 56 type)

CZ-P160SVK2 (for 73 - 106 type)

### Remote temperature sensor



CZ-CSRC3

- This is a remote sensor which can be used with indoor units. Use it to detect the room temperature when no remote controller sensor or body sensor is used (connection to a system without a remote controller is possible).
- For joint use with a remote control switch, use the remote control switch as main remote controller.

# FSV Indoor Units Range

Wide choice of models depending on the indoor requirements

Class	22	28	36	45	56	60	73
Capacity	Cooling/Heating	Cooling/Heating	Cooling/Heating	Cooling/Heating	Cooling/Heating	Cooling/Heating	Cooling/Heating
Type	2.2/2.5 7,500/8,500	2.8/3.2 9,600/11,000	3.6/4.2 12,000/14,000	4.5/5.0 15,000/17,000	5.6/6.3 19,000/21,000	6.0/7.1 20,400/24,200	7.3/8.0 25,000/27,000
F2 type <b>ECONAVI</b> Mid Static Ducted	S-22MF2E5A	S-28MF2E5A	S-36MF2E5A	S-45MF2E5A	S-56MF2E5A	S-60MF2E5A	S-73MF2E5A
M1 type <b>ECONAVI</b> Slim Low Static Ducted	S-22MM1E5A	S-28MM1E5A	S-36MM1E5A	S-45MM1E5A	S-56MM1E5A		
Z1 type <b>ECONAVI</b> Slim Low Static Ducted Twenty Series	S-22MZ1H4A	S-28MZ1H4A	S-36MZ1H4A	S-45MZ1H4A	S-56MZ1H4A	S-60MZ1H4A	S-73MZ1H4A
E2 type High Static Ducted / Energy Saving High-Fresh Air Ducted							
E1 type High Static Ducted							S-73ME1E5
H1 type High Fresh Air Ducted							
<b>NEW</b> (Class of 45 - 106) K2 type <b>ECONAVI</b> Wall Mounted	S-22MK2E5A	S-28MK2E5A	S-36MK2E5A	S-45MK2E5A	S-56MK2E5A		S-73MK2E5A
<b>NEW</b> U2 type <b>ECONAVI</b> ** 4-Way Cassette Panel No. CZ-KPU3 Panel No. CZ-KPU3A	S-22MU2E5A	S-28MU2E5A	S-36MU2E5A	S-45MU2E5A	S-56MU2E5A	S-60MU2E5A	S-73MU2E5A
Y2 type <b>ECONAVI</b> 4-Way Mini Cassette Panel No. CZ-KPY3A	S-22MY2E5A	S-28MY2E5A	S-36MY2E5A	S-45MY2E5A	S-56MY2E5A		
L1 type 2-Way Cassette Panel No. CZ-02KPL2 Panel No. CZ-03KPL2 (Only for S-73ML1E5)	S-22ML1E5	S-28ML1E5	S-36ML1E5	S-45ML1E5	S-56ML1E5		S-73ML1E5
D1 type 1-Way Cassette Panel No. CZ-KPD2		S-28MD1E5	S-36MD1E5	S-45MD1E5	S-56MD1E5		S-73MD1E5
T2 type <b>ECONAVI</b> Ceiling			S-36MT2E5A	S-45MT2E5A	S-56MT2E5A		S-73MT2E5A
P1 type Floor Standing	S-22MP1E5	S-28MP1E5	S-36MP1E5	S-45MP1E5	S-56MP1E5		S-71MP1E5
R1 type Concealed Floor Standing	S-22MR1E5	S-28MR1E5	S-36MR1E5	S-45MR1E5	S-56MR1E5		S-71MR1E5

\* Only for High Static Ducted  
\*\* Only for CZ-KPU3A

90	106	140	160	180	224	280	Wireless remote control	Functions
Cooling/Heating	Cooling/Heating	Cooling/Heating	Cooling/Heating	Cooling/Heating	Cooling/Heating	Cooling/Heating	Type with built-in sensor	Type with separately installed sensor
9.0/10.0 30,000/34,000	10.6/11.4 36,000/39,000	14.0/16.0 47,800/54,600	16.0/18.0 54,600/61,500	18.0/20.0 61,400/68,200	22.4/25.0 76,400/85,300	28.0/31.5 95,500/107,500		
S-90MF2E5A	S-106MF2E5A	S-140MF2E5A	S-160MF2E5A					self-diagnosing Auto fan MILD DRY Auto restart Drain pump DC motor
								self-diagnosing Auto fan MILD DRY Auto restart Drain pump DC motor
								self-diagnosing Auto fan MILD DRY Auto restart DC motor
				S-180ME2E5*	<b>High Fresh Air</b> S-224ME2E5	<b>High Fresh Air</b> S-280ME2E5		self-diagnosing Auto fan MILD DRY Auto restart DC motor
	S-106ME1E5	S-140ME1E5			S-224ME1E5	S-280ME1E5		self-diagnosing Auto fan MILD DRY Auto restart
		<b>High Fresh Air</b> S-140MH1H5			<b>High Fresh Air</b> S-224MH1H5	<b>High Fresh Air</b> S-280MH1H5		self-diagnosing Auto fan Auto restart
	S-106MK2E5A							self-diagnosing Auto fan MILD DRY Auto restart Air swing DC motor
S-90MU2E5A	S-106MU2E5A	S-140MU2E5A	S-160MU2E5A					self-diagnosing Auto fan MILD DRY Auto restart Air swing Drain pump DC motor
								self-diagnosing Auto fan MILD DRY Auto restart Air swing Drain pump DC motor
								self-diagnosing Auto fan MILD DRY Auto restart Air swing Drain pump DC motor
	S-106MT2E5A	S-140MT2E5A						self-diagnosing Auto fan MILD DRY Auto restart Air swing DC motor
								self-diagnosing Auto fan MILD DRY Auto restart
								self-diagnosing Auto fan MILD DRY Auto restart

Self-diagnosing function  
 Automatic fan operation  
 **DRY** Mild dry  
 Intelligent auto flap control  
 Automatic restart function for power failure  
 Air swing  
 Built-in drain pump  
 DC motor



# F2 TYPE Mid Static Ducted

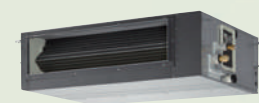

S-60MF2E5A / S-73MF2E5A / S-90MF2E5A



S-106MF2E5A / S-140MF2E5A / S-160MF2E5A



S-22MF2E5A / S-28MF2E5A / S-36MF2E5A / S-45MF2E5A / S-56MF2E5A

**ECONAVI**  
ECONAVI ready



CZ-CENSC1 CZ-RTC5A



For all indoor units CZ-RWSK2 + CZ-RWSC3

## Technical focus

- Variable external static pressure control
- Industry-leading low sound levels from 25 dB(A)
- Built-in drain pump provides 702 mm lift
- Easy to install and maintain
- Air off sensor avoids cold air drafts during heating operation
- Configurable air temperature control
- Anti-mould washable filters included

### Variable external static pressure control

Optimal airflow set-up is possible depending on ducting design and conditions.

For short ducting such as hotels

10Pa

Optimal Control by DC Motor

150Pa

For long ducting or for usage with high efficiency filter

\* Please refer to technical databook for detail.

### System example

An inspection port (450 mm x 450 mm or larger) is required at the lower side of the indoor unit body.

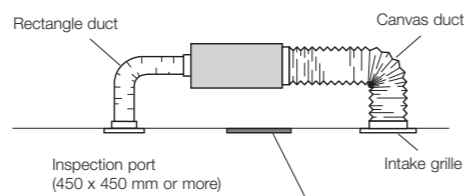

Model Name		S-22MF2E5A	S-28MF2E5A	S-36MF2E5A	S-45MF2E5A	S-56MF2E5A
Power source		220/230/240V, 1 phase - 50/60Hz				
Cooling capacity	kW	2.2	2.8	3.6	4.5	5.6
	BTU/h	7,500	9,600	12,000	15,000	19,000
Heating capacity	kW	2.5	3.2	4.2	5.0	6.3
	BTU/h	8,500	11,000	14,000	17,000	21,000
Power input	Cooling kW	0.070/0.070/0.070	0.070/0.070/0.070	0.070/0.070/0.070	0.070/0.070/0.070	0.100/0.100/0.100
	Heating kW	0.070/0.070/0.070	0.070/0.070/0.070	0.070/0.070/0.070	0.070/0.070/0.070	0.100/0.100/0.100
Running amperes	Cooling A	0.60/0.57/0.56	0.60/0.57/0.56	0.60/0.57/0.56	0.60/0.57/0.56	0.77/0.74/0.71
	Heating A	0.60/0.57/0.56	0.60/0.57/0.56	0.60/0.57/0.56	0.60/0.57/0.56	0.77/0.74/0.71
Fan motor	Type	Sirocco fan				
	Air flow rate (H/M/L) m³/h	840/780/540	840/780/540	840/780/540	840/780/600	960/900/720
	L/s	233/217/150	233/217/150	233/217/150	233/217/167	267/250/200
	Output kW	0.119	0.119	0.119	0.119	0.119
External static pressure	Pa	70(10-150)				
Power sound level (H/M/L)	dB(A)	55/51/47				
Sound pressure sound (H/M/L)	dB(A)	33/29/25				
Dimensions	H x W x D mm	290x800x700				
	Liquid mm (inches)	Ø6.35 (Ø1/4)				
Pipe connections	Gas mm (inches)	Ø12.7 (Ø1/2)				
	Drain piping	VP-25				
Net weight	kg	29				

GLOBAL REMARKS	Rated conditions:	
	Cooling	Heating
	Indoor air temperature	27°C DB / 19°C WB
Outdoor air temperature	35°C DB / 24°C WB	7°C DB / 6°C WB

Specifications are subject to change without notice.

### More powerful drain pump

Using a high-lift drain pump, drain piping can be elevated up to 702 mm from the base of the unit.

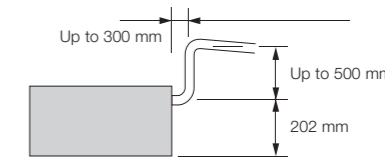

### Built-in drain pump (DC motor pump)

### Standardised height of 290 mm for all models

Height standardisation enables easy and uniform installation for models with different capacities.

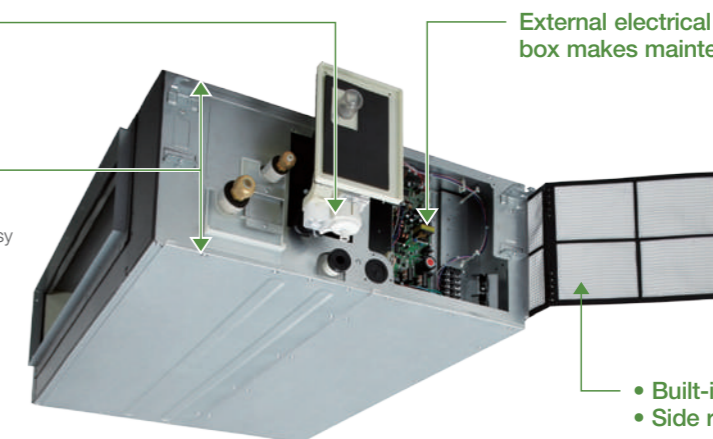

External electrical equipment box makes maintenance easy

- Built-in filter
- Side removable filter

### Discharge air temperature control

- Possible to control discharge air temperature for accurate room temperature control.
- Possible to reduce cold drafts during heating operation.

Before spec-in, please consult with an authorised Panasonic dealer.

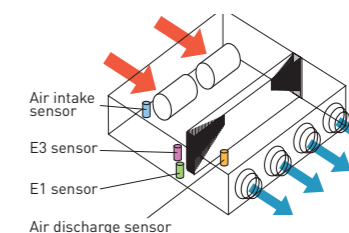

### V-shaped heat exchanger

To improve heat exchange efficiency, an original V-shaped heat exchanger was developed incorporating a conventional high-efficiency slit fan and high-efficiency grooved heat transfer tubes. This increases the heat exchange surface area by about 80%.

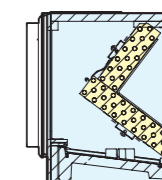

Increases surface area by about 30 to 80%

S-60MF2E5A	S-73MF2E5A	S-90MF2E5A	S-106MF2E5A	S-140MF2E5A	S-160MF2E5A
220/230/240V, 1 phase - 50/60Hz					
6	7.3	9.0	10.6	14.0	16.0
20,400	25,000	30,000	36,000	47,800	54,600
7.1	8.0	10.0	11.4	16.0	18.0
24,200	27,000	34,000	39,000	54,600	61,500
0.120/0.120/0.120	0.120/0.120/0.120	0.135/0.135/0.135	0.195/0.195/0.195	0.215/0.215/0.215	0.225/0.225/0.225
0.120/0.120/0.120	0.120/0.120/0.120	0.135/0.135/0.135	0.200/0.200/0.200	0.210/0.210/0.210	0.225/0.225/0.225
0.91/0.89/0.87	0.91/0.89/0.87	0.99/0.97/0.95	1.35/1.30/1.27	1.48/1.44/1.39	1.55/1.50/1.47
0.91/0.89/0.87	0.91/0.89/0.87	0.99/0.97/0.95	1.37/1.34/1.29	1.46/1.42/1.38	1.55/1.50/1.46
Sirocco fan	Sirocco fan	Sirocco fan	Sirocco fan	Sirocco fan	Sirocco fan
1,260/1,140/900	1,260/1,140/900	1,500/1,380/1,140	1,920/1,560/1,260	2,040/1,740/1,380	2,160/1,920/1,500
350/317/250	350/317/250	417/383/317	533/433/350	567/483/383	600/533/417
0.124	0.124	0.124	0.235	0.235	0.235
70(10-150)	70(10-150)	70(10-150)	100(10-150)	100(10-150)	100(10-150)
57/54/48	57/54/48	59/56/50	60/56/53	61/57/54	62/58/55
35/32/26	35/32/26	37/34/28	38/34/31	39/35/32	40/36/33
290x1,000x700	290x1,000x700	290x1,000x700	290x1,400x700	290x1,400x700	290x1,400x700
Ø9.52 (Ø3/8)	Ø9.52 (Ø3/8)	Ø9.52 (Ø3/8)	Ø9.52 (Ø3/8)	Ø9.52 (Ø3/8)	Ø9.52 (Ø3/8)
Ø15.88 (Ø5/8)	Ø15.88 (Ø5/8)	Ø15.88 (Ø5/8)	Ø15.88 (Ø5/8)	Ø15.88 (Ø5/8)	Ø15.88 (Ø5/8)
VP-25	VP-25	VP-25	VP-25	VP-25	VP-25
34	34	34	46	46	46

# M1 TYPE Slim Low Static Ducted Concealed duct



S-22MM1E5A /  
S-28MM1E5A /  
S-36MM1E5A /  
S-45MM1E5A /  
S-56MM1E5A

**ECONAVI**  
ECONAVI ready



For all indoor units  
CZ-RWSK2 +  
CZ-RWSC3

# Z1 TYPE Slim Low Static Ducted Twenty Series Concealed duct



S-22MZ1H4A/ S-28MZ1H4A/ S-36MZ1H4A/  
S-45MZ1H4A/ S-56MZ1H4A/ S-60MZ1H4A



S-73MZ1H4A

**ECONAVI**  
ECONAVI ready



For all indoor units  
CZ-RWSK2 +  
CZ-RWSC3

## Technical focus

- Ultra-slim profile: 200 mm for all models
- DC fan motor greatly reduces power consumption
- Ideal for hotel application with very narrow false ceilings
- Anti-mould washable filters included
- Easy maintenance and service by external electrical box
- 40 Pa static pressure enables ductwork to be fitted.
- Includes drain pump

### Ultra-slim profile for all models

200mm height for all models allows installation in very narrow ceilings.



### Drain pump with increased power

Using the built-in high-lift drain pump, the drain piping rise height can be increased to 653 mm from the lower surface of the body.

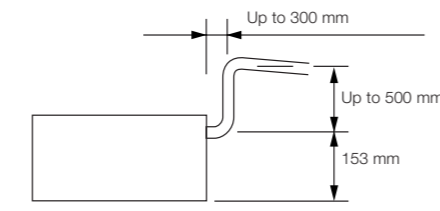

Model Name		S-22MM1E5A	S-28MM1E5A	S-36MM1E5A	S-45MM1E5A	S-56MM1E5A	
Power source		220/230/240 V, 1 phase - 50 / 60 Hz					
Cooling capacity	kW	2.2	2.8	3.6	4.5	5.6	
	BTU/h	7,500	9,600	12,000	15,000	19,000	
Heating capacity	kW	2.5	3.2	4.2	5.0	6.3	
	BTU/h	8,500	11,000	14,000	17,000	21,000	
Power input	Cooling kW	0.036/0.036/0.036	0.040/0.040/0.040	0.042/0.042/0.042	0.049/0.049/0.049	0.064/0.064/0.064	
	Heating kW	0.026/0.026/0.026	0.030/0.030/0.030	0.032/0.032/0.032	0.039/0.039/0.039	0.054/0.054/0.054	
Running current	Cooling A	0.26/0.26/0.26	0.30/0.30/0.30	0.31/0.31/0.31	0.37/0.37/0.37	0.48/0.48/0.48	
	Heating A	0.23/0.23/0.23	0.27/0.27/0.27	0.28/0.28/0.28	0.34/0.34/0.34	0.45/0.45/0.45	
Fan	Type	Sirocco fan					
	Air flow rate (H/M/L)	m³/h	480/420/360	510/450/390	540/480/420	630/570/480	750/690/600
		L/s	133/117/100	142/125/108	150/133/117	175/158/133	208/192/167
	Motor output	kW 0.05					
	External static pressure	Pa 10 (30)					
Sound power level (H/M/L)	dB	43/42/40	45/44/42	47/45/43	49/47/45	52/50/48	
Sound pressure level (H/M/L)	dB(A)	28/27/25 (30/29/27)*	30/29/27 (32/31/29)*	32/30/28 (34/32/30)*	34/32/30 (36/34/32)*	35/33/31 (37/35/32)*	
Dimensions	H x W x D	mm 200 x 750 x 640					
Pipe connections	Liquid	mm (inches) Ø6.35 (Ø1/4)					
	Gas	mm (inches) Ø12.7 (Ø1/2)					
	Drain piping	VP-20					
Net weight	kg	19					

Specifications are subject to change without notice.

\* With booster cable.

Global remarks	Rated conditions:	
	Cooling	Heating
	Indoor air temperature	27°C DB / 19°C WB
Outdoor air temperature	35°C DB / 24°C WB	7°C DB / 6°C WB

## Technical focus

- Ultra-slim profile: 200 mm for all models
- DC fan motor greatly reduces power consumption
- Ideal for hotel application with very narrow false ceilings
- Easy maintenance and service by external electrical box
- 29 Pa static pressure enables ductwork to be fitted.
- Drain pump (optional)

### Ultra-slim profile for all models

200mm height for all models allows installation in very narrow ceilings.



### Drain pump with increased power (optional)

Using the optional high-lift drain pump, the drain piping rise height can be increased to 700 mm from the drain pipe port.

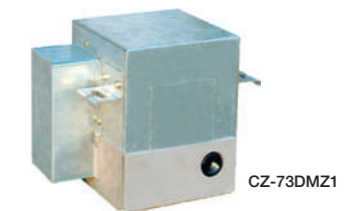

Model Name		S-22MZ1H4A	S-28MZ1H4A	S-36MZ1H4A	S-45MZ1H4A	S-56MZ1H4A	S-60MZ1H4A	S-73MZ1H4A	
Power source		220/230/240 V, 1 phase - 50 / 60 Hz							
Cooling capacity	kW	2.2	2.8	3.6	4.5	5.6	6.0	7.3	
	BTU/h	7,500	9,500	12,200	15,300	19,100	20,500	24,900	
Heating capacity	kW	2.5	3.2	4.2	5.1	6.4	7.1	8.0	
	BTU/h	8,500	10,900	14,300	17,400	21,800	24,200	27,300	
Power input	Cooling kW	0.075/0.075/0.075	0.080/0.080/0.080	0.085/0.085/0.085	0.095/0.095/0.095	0.100/0.100/0.100	0.100/0.100/0.100	0.125/0.125/0.125	
	Heating kW	0.075/0.075/0.075	0.080/0.080/0.080	0.085/0.085/0.085	0.095/0.095/0.095	0.100/0.100/0.100	0.100/0.100/0.100	0.125/0.125/0.125	
Running current	Cooling A	0.50/0.47/0.45	0.55/0.52/0.50	0.60/0.57/0.55	0.70/0.68/0.65	0.75/0.72/0.70	0.75/0.72/0.70	0.80/0.78/0.75	
	Heating A	0.50/0.47/0.45	0.55/0.52/0.50	0.60/0.57/0.55	0.70/0.68/0.65	0.75/0.72/0.70	0.75/0.72/0.70	0.80/0.78/0.75	
Fan	Type	Sirocco fan							
	Air flow rate (H/M/L)	m³/h	480/420/360	600/540/420	600/540/420	690/630/510	720/660/540	870/750/630	1,080/840/660
		L/s	133/117/100	167/150/117	167/150/117	192/175/142	200/183/150	242/208/175	300/233/183
	Motor output	W 60							
	External static pressure	Pa 10-30							
Sound power level (H/M/L)	dB	50/49/47	52/51/49	54/52/50	56/54/52	57/55/53	60/57/55	62/60/58	
Sound pressure level (H/M/L)	dB(A)	28/27/25	30/29/27	32/30/28	34/32/30	35/33/31	38/35/33	40/38/36	
Dimensions	H x W x D	mm 200x830x500		mm 200x830x500		mm 200x830x500		mm 200x1,050x550	
Pipe connections	Liquid	mm (inches) Ø6.35 (Ø1/4)							
	Gas	mm (inches) Ø12.7 (Ø1/2)							
	Drain piping	O.D. Ø20.5 mm / I.D. Ø15.5mm							
Net weight	kg	17		18		18		24	

Specifications are subject to change without notice.

Global remarks	Rated conditions:	
	Cooling	Heating
	Indoor air temperature	27°C DB / 19°C WB
Outdoor air temperature	35°C DB / 24°C WB	7°C DB / 6°C WB



# Connected to the Future. VRF Smart Connectivity

Through thorough energy management, Panasonic's VRF Smart Connectivity is a completely new, state-of-the-art solution providing energy saving and comfort as well as simple installation, operation and running.

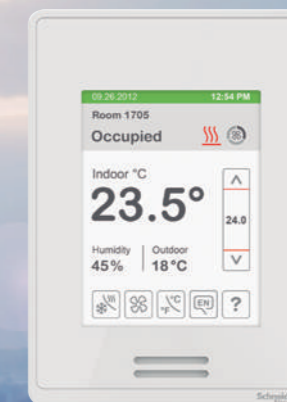

## VRF Smart Connectivity. The future of control.

A remote controller is all that's required for occupancy control and optimum automatic indoor air quality (IAQ) control. Simple operation with a rented interface further contributes to increased energy efficiency and productivity for reduced capital expenditure (CapEx) and operating expense (OpEx).

**For building end users**  
**COMFORT (IAQ)**

**For business partners**  
**EASY INSTALLATION AND INTEGRATION**

**For building owners**  
**CapEx**

**For building owners**  
**OpEx**

Extremely simple Plug and Play connection to a Building Energy Management System (BEMS) is possible. Compared to the current VRF systems and chillers of other companies, connection is smooth and stress-free, so there's considerably less burden on the system integrator.

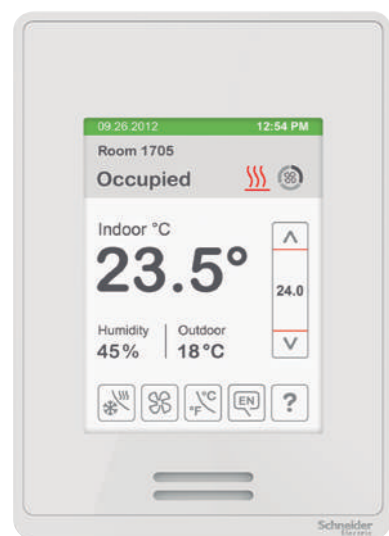

## VRF Smart Connectivity advantages

- Easy design and plug and play to reduce CapEx.**
  - Simple Plug & Play VRF connection to Building Energy Management System (BEMS)
  - Stand alone or BEMS connected
  - VRF indoor Wired or Wireless connection
  - Plug and play additional ZigBee sensors

- Dramatic Reduction of OpEx with Outstanding IAQ.**
  - 2 Built in sensors: Temperature and RH
  - ZigBee wireless sensors: CO<sub>2</sub>, window/door, human presence.

- Ultimate customization.**
  - Background colour customisable
  - Custom display/icons, messages
  - Set point boundaries
  - Programmable logic (also stand alone)

- User-/Owner-friendly.**
  - Colour touch screen
  - Ease and simply of use
  - 20 Languages
  - Easy to understand error description

## What is VRF Connectivity?

### Stand alone Smart Connection

VRF Smart connectivity connects Panasonic the all indoor units by wired or wireless connection.

#### Wired solution.

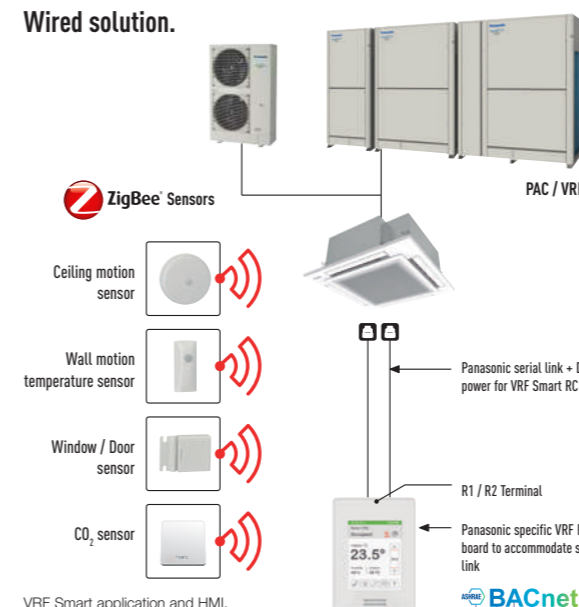

VRF Smart application and HMI. Powered over communication serial link. BACnet, Modbus, ZigBee. One RC to one VRF FCU.

1. When using wired solution, VCM8000V5094P will be required to connect with Zigbee Sensors.

#### Wireless solution.

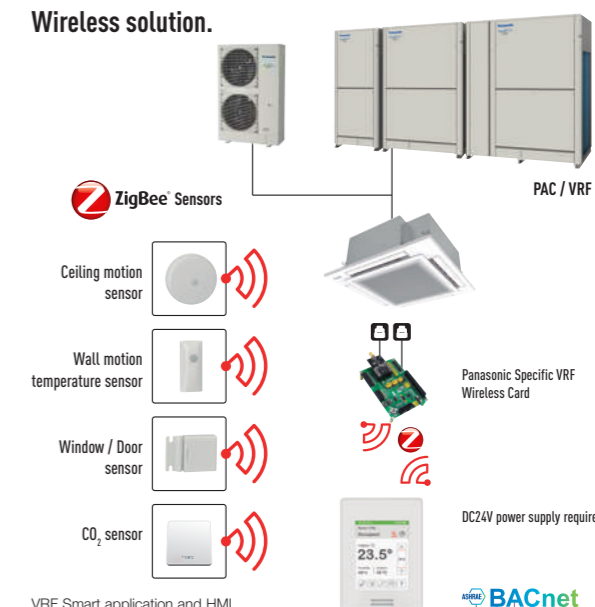

VRF Smart application and HMI. Normal Power Supply. BACnet, Modbus, ZigBee. One RC to one VRF FCU.

## Sensing technology

The wireless solution using sensors born from the collaboration between Panasonic and Schneider Electric enables easy installation in existing and old buildings in which wiring is difficult (installation in a wired environment is also possible). The result is high-quality occupancy control and automatic IAQ control. The sensors detect the presence or absence of occupants, and the opening and closing of doors and windows to achieve the most efficient energy management for exceptional air-conditioned comfort. Flexible installation is possible to match different applications and building features such as walls, ceilings and closeness to doors and windows. No wiring means extra installation versatility.

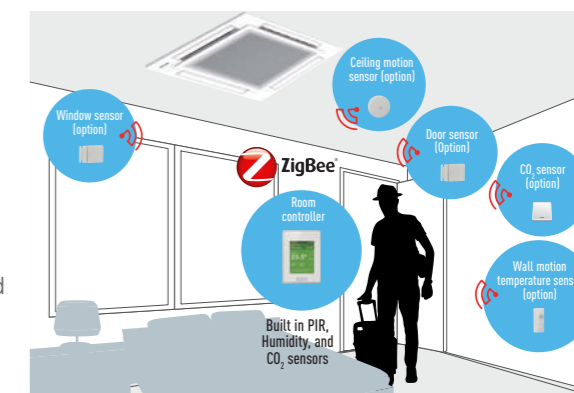

Batteries last for up to five years and are easy to install and replace.

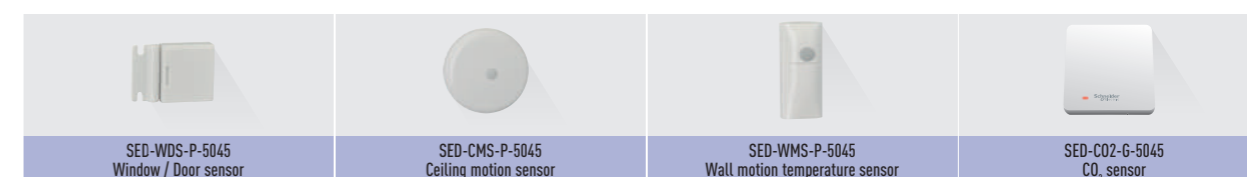

# VRF Smart Connectivity



## BEMS Smart Connection

The Smarter solution to simplify energy management, optimize building efficiency and drive savings.

### Plug and play BEMS connection.

With Plug and Play, connection to a BEMS is extremely easy. Better still, a remote controller is all that's needed to enable use as a stand-alone system. As well as dramatically reducing the burden on system integrators, this cuts costs.

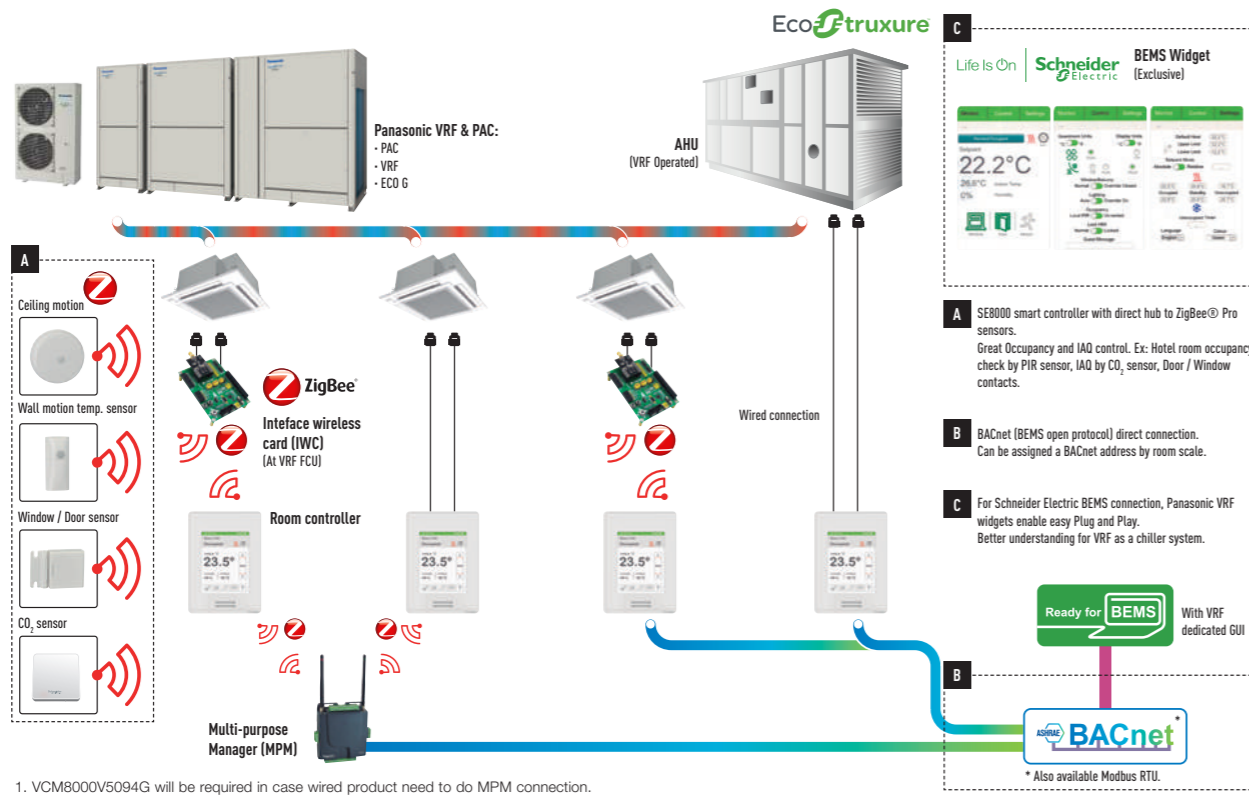

1. VCM8000V5094G will be required in case wired product need to do MPM connection.

## BEMS conventional system vs VRF Smart Connectivity

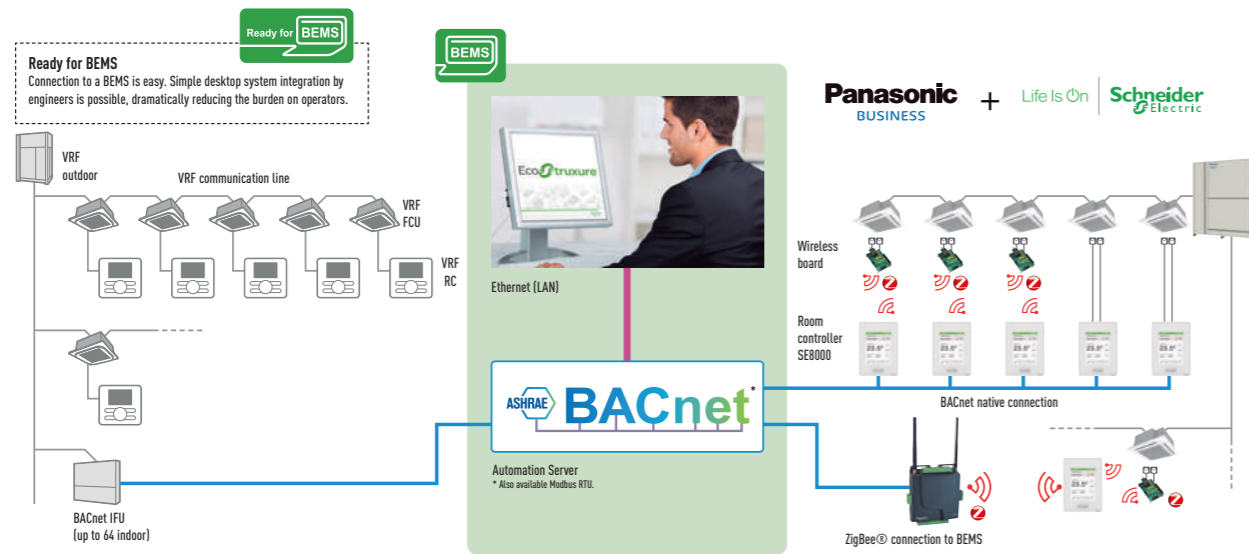

	Conventional	VRF Smart Connectivity	Advantage
<b>Hardware connection</b>	Need 2 Hardware CZ-CFUNC2 + BMS I/F	Required BACnet objects manual Wired/wireless	CapEx: Saving interfaces
<b>Integration</b>	Manual system integration per indoor	Advanced plug & play connection	CapEx: Integrator time
	Required BACnet objects manual	Advanced plug & play connection	CapEx: Integrator time / OpEx: Full Integration of VRF signals

## Innovative and unrivalled advantages

### Stand alone Smart Connection VRF.

#### CO2 and humidity sensors for high IAQ

CO2 sensors taking measurements in units of ppm, and humidity sensors enable fine air quality control. This creates the most comfortable space for occupants while contributing to improved employee satisfaction.



### VRF wireless connection

Layout is extremely important because it decides how members of staff spend their time and work in an office. Until now, changing the layout of an office was difficult because of the complicated wiring involved, but with wireless VRF connection it's no trouble at all and more flexible layout is possible.

### Energy management for high return on investment (ROI)

Avoid the huge costs that occur when the control of air conditioning is left to staff with a tailor-made solution. Automatically controlled operation with precise settings reduces both wasted energy and running costs. This in turn contributes to improved ROI which is directly linked to management.

### Installation possible during business hours without closing the store

To install a new system, it was previously necessary to close stores and restaurants. Now, thanks to Panasonic's wireless technology, smart installation is possible without closing an establishment or performing building work such as knocking down walls. And the enjoyment of customers isn't interrupted.

### Colour and design to match office interiors

When creating an office environment, a stylish appearance that complements the design of the office rather than interfering with it is an important consideration. Colour combinations and design can be set to match different facilities.

### Easy-to-understand error description

Error description during an emergency is easy to understand, enabling staff to respond quickly. By eliminating the wasted cost of calling a service person every time there's a problem, this reduces total annual maintenance costs.

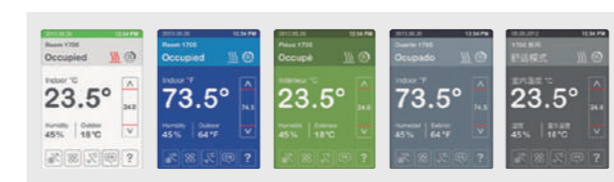

# VRF Smart Connectivity



Guest room management solutions for hotels.  
Deliver exceptional guest satisfaction while optimizing energy and operational efficiency.

## Customization in approx. 20 languages possible

The display can be customized to match the native languages of guests to enable smooth, stress-free communication for hospitality at its finest.



## Occupancy sensors enabling automatic control for outstanding efficiency

Sensors in the room and on the controller detect the presence or absence of occupants and the opening and closing of windows and doors. While maintaining the optimum air-conditioned environment guests expect, automatic control ensures the most efficient operation when they are away or when windows are open. This contributes to an appreciable reduction in operation costs.

## A truly comfortable experience for guests

Easy-to-understand, refined on-screen images enable display of hotel logos and original welcoming messages. Colour and design can also be customized for different facilities to create an even more comfortable environment for guests.



## VRF Smart Connectivity devices

2 types of devices depending on type connection with indoor units wireless or wired.  
Wireless connection to indoor unit requires ZigBee interface for indoor unit.



Schneider Electric brand - SE8000



- Features**
- Up to 5-year battery life, batteries included
  - Battery level is a point
  - Sensor points visible in SBO when SE8000 is integrated via BACnet MS/TP
  - Sensor status and battery level visible in SBE when SE8000 is integrated via ZigBee® Pro
  - Integration to SBE only recommended when each MPM is connected to Ethernet and are set as ZigBee® Coordinator nodes

Remote Controller	Description
SER8150R081194	Panasonic Net Con, RH, No PIR, R1/R2 (Wired)
SER8150R581194	Panasonic Net Con, RH, PIR, R1/R2 (Wired)
SER8150A081194P *	Panasonic Net Con, RH, No PIR, ZB (Wireless)
SER8150A581194P *	Panasonic Net Con, RH, PIR, ZB (Wireless)
Interface	Description
VCM8000V5094P	Panasonic wireless Zigbee Pro Com.card
VCM8000R94BOX *	Panasonic R1/R2 (Wired) to Zigbee adaptor box No Brand
VCM8000V5094G *	Wireless Zigbee Pro / Green Com card

Sensor	Description
SED-WMS-P-5045	SED SEN OCC WALL ZP
SED-WDS-P-5045	SED SW DOR/WIN ZP
SED-CMS-P-5045	SED SEN OCC CEIL ZP
SED-CO2-G-5045 *	Wireless Zigbee Green CO2 sensor
Fascia	Description
FAS-00	Silver
FAS-01	White
FAS-03	Translucent White
FAS-05	Light Tan Wood
FAS-06	Dark Brown Wood
FAS-07	Dark Black Wood
FAS-10	Brushed Steel

1. VCM8000V5094P : Required in case wired solution connecting with Zigbee Sensors.  
2. VCM8000V5094G : Required in case wired solution need to do MPM connection.  
3. As for the products marked with\*, the time of release will be announced later.

## VRF Smart Connectivity controller external dimensions

### Room Controller for VRF SE8000

#### Dimensions

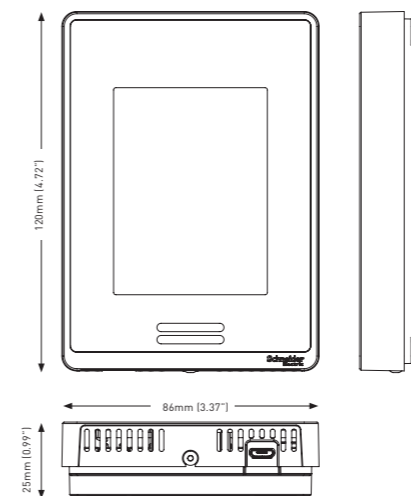

#### Specifications

**Dimensions**  
Height: 12cm/4.72in  
Width: 8.6cm/3.39in  
Depth: 2.7cm/1.06in

**SE8000 Power Requirements**  
16 Vdc from Panasonic R-R IDU connectors  
24V, 50-60Hz, Class 2, 4VA

**Operating Conditions**  
0 °C to 50 °C ( 32 °F to 122 °F)  
0% - 75% R.H. non-condensing

**Storage Conditions**  
-30 °C to 50 °C ( -22 °F to 122 °F)  
0% to 75% R.H. non-condensing

**Temperature Sensor**  
Local 10 K NTC type 2 thermistor  
**Temperature Sensor Resolution**  
± 0.1 °C ( ± 0.2 °F)

**Temperature Control Accuracy**  
± 0.5 °C ( ± 0.9 °F) @ 21 °C ( 70 °F) typical calibrated

**Humidity Sensor and Calibration**  
Single point calibrated bulk polymer type sensor  
**Humidity Sensor Precision**  
Reading range from 10 to 90 % R.H. non-condensing 10 to 20% precision: 10%  
20% to 80% precision: 5%  
80% to 90% precision: 10%

**Humidity Sensor Stability**  
Less than 1.0 % yearly (typical drift)

**Dehumidification Setpoint Range**  
30% to 95% R.H.

**Safety Standards All Models**  
LVD Directive 2006/95/EC  
EN 60950-1-2006/A2-2013UL 873  
CSA C22.2 No. 24-93

**EMC Standards All Models**  
EMC Directive 2004/108/EC  
IEC 61326-1:2005  
FCC 15 Subpart B  
ICES-003

**Radio Standards (Wireless Models)**  
R&TTE Directive 1999/5/EC  
ETSI EN 300 328 V1.8.1  
ETSI EN 301 489-1 V1.9.2  
ETSI EN 301 328 V1.8.1  
FCC 15 Subpart C, Class A  
RSS 210

**Occ, Stand-By and Unocc Cooling Setpoint Range**  
12.0 to 37.5 °C ( 54 to 100 °F)

**Occ, Stand-By and Unocc Heating Setpoint Range**  
4.5 °C to 32 °C ( 40 °F to 90 °F)

**Room and Outdoor Air Temperature Display Range**  
-40 °C to 50 °C ( -40 °F to 122 °F)

**Proportional Band for Room Temperature control**  
Cooling & Heating: Default: 1.8°C ( 3.2°F)

**Binary Inputs**  
Dry contact across terminal BI1, BI2 and UI3 to 5com.

**Wire Gauge**  
Power supply: 18 gauge or larger  
Communication: 24 gauge or larger

**Fan Line Voltage Contact Electrical Ratings**  
Orange wire, 10A maximum  
**Cool Line Voltage Electrical Ratings**  
Yellow wire, 5A maximum

**Output Ratings**  
Fan: Brown, Blue, Red wires 1/2 HP or 13A at 277Vac maximum.

**Approximate Shipping Weight**  
0.34 kg (0.75 lb)

**Main Heat Voltage Electrical Ratings**  
Orange wire, 10A maximum

**Cool Line Voltage Electrical Ratings**  
Yellow wire, 5A maximum

THIS DEVICE COMPLIES WITH PART 15 OF THE FCC RULES. OPERATION IS SUBJECT TO THE FOLLOWING TWO CONDITIONS: (1) THIS DEVICE MAY NOT CAUSE HARMFUL INTERFERENCE, AND (2) THIS DEVICE MUST ACCEPT ANY INTERFERENCE RECEIVED, INCLUDING INTERFERENCE THAT MAY CAUSE UNDESIRABLE OPERATION.



Check with your local government for instruction on disposal of these products.

THIS PRODUCT FOR COMMERCIAL USE ONLY

### Ceiling motion sensor SED-CMS-P-5045

#### Dimensions

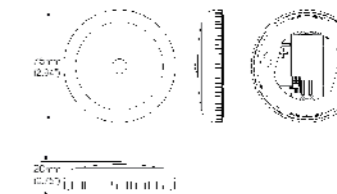

#### Specifications

**Dimensions**  
75mm diameter x 20mm thick (2.94in diameter x 0.75in thick)

**Color**  
White

**Weight**  
50g (1.8oz) with batteries

**Communication**  
ZigBee®, HA1.2 Compatible

**Communication Range**  
Up to 40ft (12m), open field 300ft (100m)

**Detection Range**  
Maximum: 90 deg cone, 16.5ft (5m) Recommended: 45 deg, 12ft (3.6m)

**Battery Voltage**  
1.5VDC Alkaline

**Battery Cell**  
2 x AAA (recommended Panasonic LR03XWA)

**Battery Life**  
Up to 5 years

**Ambient Temperature**  
-10°C to +50°C (+14°F to +122°F)

**Certification**  
Check with your local government for instruction on disposal of these products.

### Wall motion sensor SED-WMS-P-5045

#### Dimensions

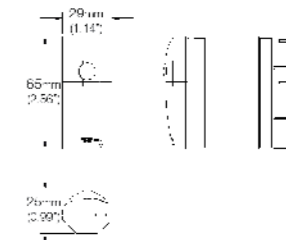

#### Specifications

**Dimensions**  
65mm W x 29mm H x 25mm D (2.56in W x 1.14in H x 0.99in DS)

**Color**  
White

**Weight**  
30g (1.06oz) with battery

**Communication**  
ZigBee®, HA1.2 Compatible

**Communication Range**  
Up to 40ft (12m) open field 300ft (100m)

**Detection Range**  
Maximum: 90 deg cone, 16.5ft (5m) Recommended: 47 deg, 16ft (5m)

**Battery Voltage**  
3.0VDC Lithium

**Battery Cell**  
CR2 (recommended Panasonic CR15H270)

**Battery Life**  
Up to 5 years

**Ambient Temperature**  
-10°C to +50°C (+14°F to +122°F)

**Certification**  
Check with your local government for instruction on disposal of these products.

### Door/window contact SED-WDS-P-5045

#### Dimensions

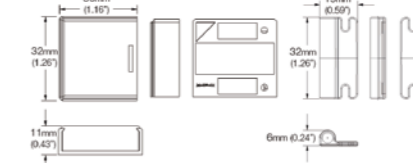

#### Specifications

**Sensor Dimensions**  
32mm W x 30mm H x 11mm D (1.26in W x 1.16in H x 0.43in D)

**Magnet Dimensions**  
15mm W x 32mm H x 6mm D (0.59" W x 1.26" H x 0.24" DSS)

**Color**  
White

**Weight**  
11g (0.38oz) with battery

**Communication**  
ZigBee®, HA1.2 Compatible

**Communication Range**  
Up to 40ft (12m) open field 300ft (100m)

**Battery Voltage**  
3.0VDC Lithium

**Battery Cell**  
CR2032 (recommended Panasonic CR2032)

**Battery Life**  
Up to 5 years

**Ambient Temperature**  
-10°C to +50°C (+14°F to +122°F)

**Certification**  
Check with your local government for instruction on disposal of these products.

# Panasonic AC Smart Cloud



## Flexible solution and scalable solution

- Energy saving
- Zero downtime
- Site(s) management

Centralize control of your business premises, from wherever you are, 24/7/365. It doesn't matter how many sites you have, or where they are! The AC Smart Cloud system from Panasonic allows you to have complete control of all your installations, from your tablet or from your computer. In a simple click, all your units from several locations, receive status updates in real-time of all your installations, preventing breakdowns and optimizing costs.

### Flexible solution for your business.

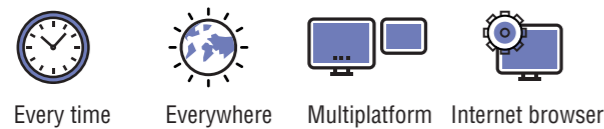

### Scalable solution for your business.

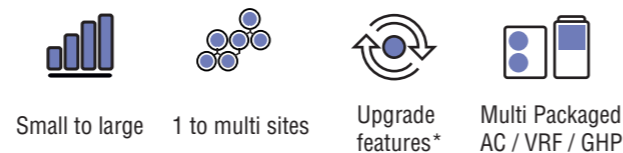

\*Customized to meet user demand / Upgraded new functions / Upgraded by new products / IT smart management.

## 3 steps to setup the Smart Cloud

Panasonic Smart Cloud is very easy to install on existing and new installations. The communication adaptor (CZ-CFUNC2 + PAW-CCA-1) is connected to the Panasonic bus and the Ethernet. Then in only 3 steps, the cloud system is running.

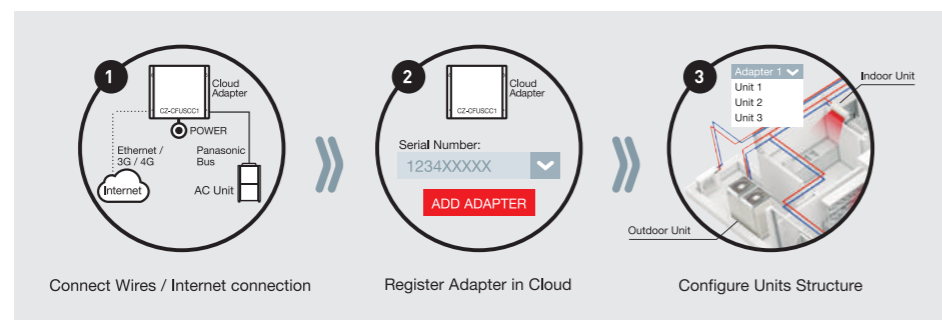

## Key functions and uniqueness

### Multi site monitoring.

- It doesn't matter how many sites you have, easy to manage, operate, compare per sites, locations, rooms.



### Powerful statistics for energy savings.

- Power consumption, capacity, efficiency level can be compared per different parameters (Yearly / monthly / weekly/ daily bases)



### Schedule setting.

- Weekly / holiday timer setting as you want
- One setting can be copied to other sites

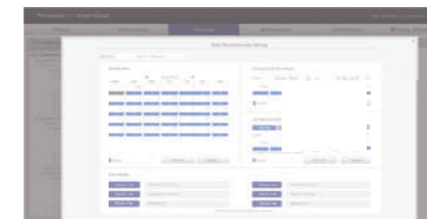

### Maintenance notification.

- Error notification by email and with floor layout
- Maintenance notification of VRF / GHP outdoor units



### User customization.

Site administrator can create users as desired and assign customized profiles.

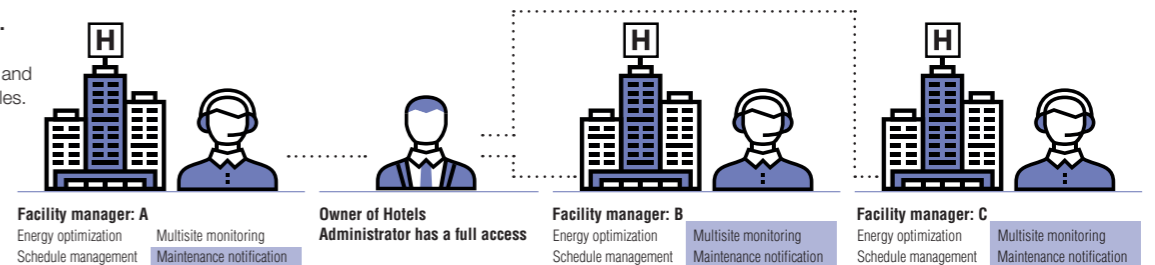

## One of our uniqueness is "Stable and secured communication package"

- Connectivity is included in the service. Customers do not have to take time to find and prepare suitable connectivity.
- With an all inclusive service offering, the customer has peace of mind and a one stop shop for all AC Smart Cloud issues they may face including connectivity field supply.



# FSV Controllers

A wide variety of control options to meet the requirements of different applications.

**ECONAVI**  
**ECONAVI Sensor**  
 CZ-CENSC1



Utilises ECONAVI Sensor and Control Program technologies to detect where energy is normally wasted and self-adjusts cooling power to reduce energy waste.

- Activity detection
- Absence detection

Operation system	Individual control systems				Timer operation
Requirements	High-spec operation	Normal operation	Operation from anywhere in the room	Quick and easy operation	Daily and weekly program
External appearance					
Type, model name	High-spec Wired Remote Controller CZ-RTC5A	Timer Remote Controller (Wired) CZ-RTC4	Wireless Remote Controller CZ-RWSU3 CZ-RWSL2N CZ-RWSC3 CZ-RWSD2 CZ-RWST3N CZ-RWSK2	Simplified Remote Controller CZ-RE2C2	Schedule Timer CZ-ESWC2
Built-in thermostat	●	●	●	●	—
ECONAVI ON/OFF control	●	●	—	—	—
Number of indoor units which can be controlled	1 group, 8 units	1 group, 8 units	1 group, 8 units	1 group, 8 units	64 groups, max. 64 units
Use limitations	· Up to 2 controllers can be connected per group (When using ECONAVI sensor, only one remote controller is possible to connect at indoor unit)	· Up to 2 controllers can be connected per group (When using ECONAVI sensor, only one remote controller is possible to connect at indoor unit)	· Up to 2 controllers can be connected per group.	· Up to 2 controllers can be connected per group.	· Required power supply from the system controller · When there is no system controller, connection is possible to the T10 terminal of an indoor unit.
Function ON/OFF	●	●	●	●	—
Mode setting	●	●	●	●	—
Fan speed setting	●	●	●	●	—
Temperature setting	●	●	●	●	—
Air flow direction	●	●	●	●	—
Permit/Prohibit switching	—	—	—	—	—
Weekly program	●	●	—	—	●

All specifications are subject to change without notice.

Centralised control systems			BMS System PC Base	Connection with 3rd Party Controller
Operation with various functions from a central location	Only ON/OFF operation from a central location	Simplified load distribution ratio (LDR) for each tenant 10.4 in. touch screen panel color LCD		
System Controller CZ-64ESMC3	ON/OFF Controller CZ-ANC3	Intelligent Controller CZ-256ESMC3 (CZ-CFUNC2)	P-AIMS Software Up to 1024 units CZ-CSWKC2	Seri-Para I/O unit for outdoor unit CZ-CAPDC2
—	—	—	Optional software 	Interface Adaptor NEW CZ-CAPC3
●	—	●	CZ-CSWAC2 for Load distribution CZ-CSWWC2 for Web application CZ-CSWGC2 for Object layout display CZ-CSWBC2 for BACnet software interface *PC required (field supply)	Seri-Para I/O unit for each indoor unit CZ-CAPBC2
64 groups, max. 64 units	16 groups, max. 64 units	64 units x 16 systems, max. 256 units		Communication Adaptor CZ-CFUNC2
· Up to 10 controllers, can be connected to one system. · Main unit/sub unit (1 main unit + 1 sub unit) connection is possible. · Use without remote controller is possible.	· Up to 8 controllers (4 main units + 4 sub units) can be connected to one system. · Use without remote controller is impossible.	· A communication adaptor (CZ-CFUNC2) must be installed for three or more links.	Web Interface Systems 	LonWorks Interface CZ-CLNC2
●	●	●		
●	—	●		
●	—	●		
●	—	●		
●	—	●		
●	●	●		
●	—	●		

# Panasonic Total Air Conditioning Management System P-AIMS

## P-AIMS basic software / CZ-CSWKC2

Up to 1024 indoor units can be controlled by one PC

### Functions of basic software

- Standard remote control for all indoor units
- Many timer schedule programs can be set on the calendar
- Detailed information display for alarms
- CSV file output with alarm history, operating status.
- Automatic data backup to HDD

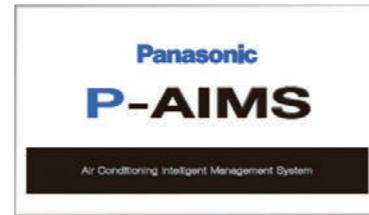

With 4 upgrade packages the basic software can be upgraded to suit individual requirements

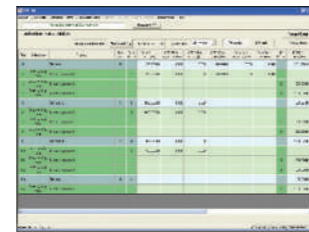
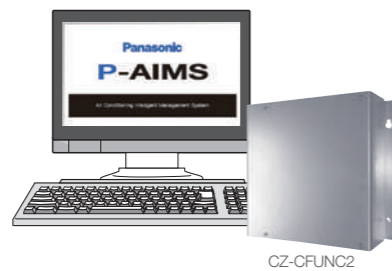

The P-AIMS is ideal for large areas/buildings such as shopping centers, universities and office buildings.

Each line can have max.8C/A units, and control max.512 units. In total, 1024 indoor units can be controlled by 1 "P-AIMS" PC.

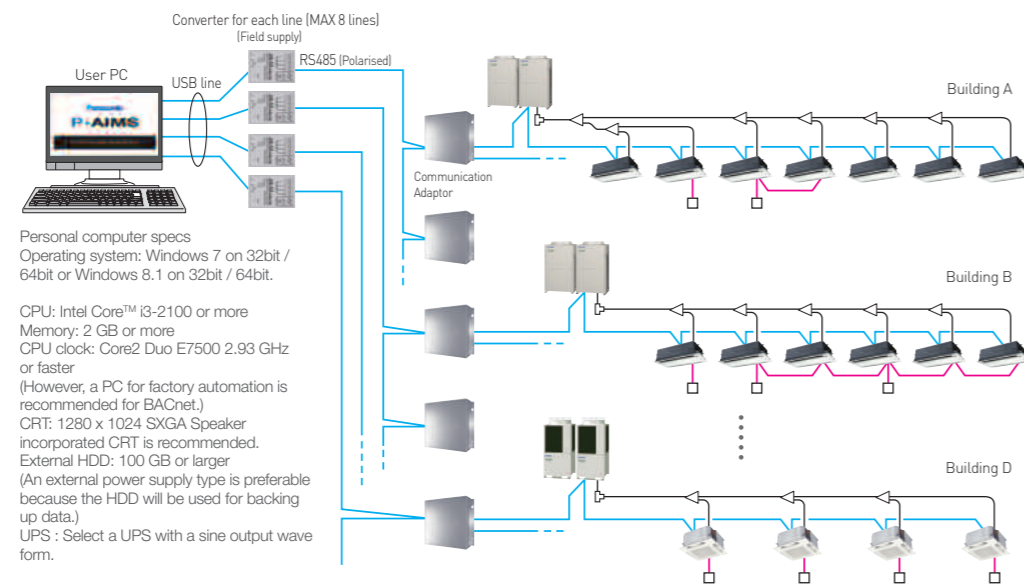

## Intelligent Controller (CZ-256ESMC3)

NEW



Touch panel

Dimensions  
 H 240 x W 280 x D 85 mm  
 Power supply AC 100 to 240 V (50/60 Hz)  
 LCD: 10.4 in. TFT, XGA(1024 x 768), LED backlight

### Product features

- 10.4 in., large, easy-to-use color LCD
- With smartphone like operations, such as swiping and flicking
- Enhanced energy-saving control functions
  - Packed with demand functions
  - Set temperature auto return settings, Auto shutoff, Set temperature range limit settings
- Energy visualization
  - Displays electricity & gas usage distribution
  - Supports energy-saving plans with graph display function

### New features

- Max 256 indoor unit [16 systems x 64 units] can be controlled. In case of three or more systems [more than 128 units], a communication adapter CZ-CFUNC2 must be installed for three or more links.
- Operation is possible as batch, in zone units, and in group units.
- ON/OFF, operation mode setting, temperature setting, for fan speed setting, air flow direction setting (when used without a remote controller) and remote controller local operation prohibition [prohibition 1,2,3,4] can be done
- Graph display [trends, comparisons]
- ECONAVI ON/OFF

- Outdoor unit quiet operation ON/OFF
- Energy-saving functions
- Event control [such as equipment linkage]
- Limitation contents for prohibited operation

Prohibition means limitation of the operation contents from the remote controller. It is also possible to change the prohibition items.

### Limitation contents (Limitations can be user defined)

- Individual There is no limitation for the operation of the remote controller. However, the contents will be changed to the contents of the controller operated last. (Last-pressed priority)
- Prohibition 1 The remote controller cannot be used for ON/OFF. (All other operations are possible from the remote controller.)
- Prohibition 2 The remote controller cannot be used for ON/OFF, operation mode change and temperature setting. (All other operations are possible from the remote controller.)
- Prohibition 3 The remote controller cannot be used for operation mode change and temperature setting. (All other operations are possible from the remote controller.)
- Prohibition 4 The remote controller cannot be used for operation mode change. (All other operations are possible from the remote controller.)

### Remote control

The LAN terminal on this unit enables you connect it to a network. Connecting to internet will enable you to operate the unit and check the status using a PC from remote location.

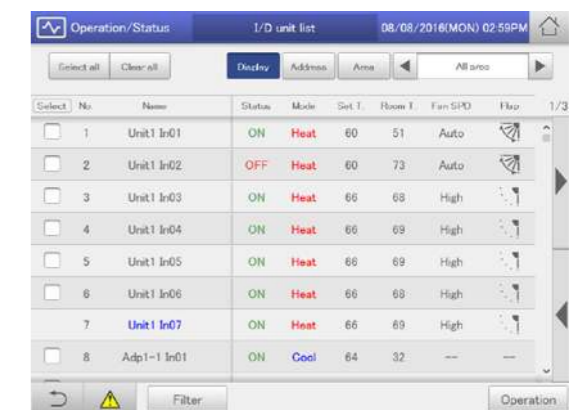

Display image on the remote PC is same design as the controller unit.



# Panasonic VRF Global Project References

Panasonic air conditioning systems provides comprehensive solutions to businesses around the world. Harnessing our advanced technology and extensive on-site expertise, we serve clients in a diverse range of environments throughout the world.

## HOTEL

**Australia** Travelodge Hobart



Air Conditioning System:  
VRF 3-way FSV MF2 series 8 systems  
Indoor Units: 116 units  
Cooling Capacity:  
302 kW / 86 USRT

**Indonesia** Patra Jasa Hotel



Air Conditioning System:  
VRF 2-way FSV ME1 series 14 systems  
Indoor Units: 132 units  
Cooling Capacity:  
677 kW / 193 USRT

**Spain** Hotel Claris 5 GL



Air Conditioning System:  
VRF 2-way ME1&LE1 series 11 systems  
VRF 3-way MF1 series 14 systems  
Indoor Units: 233 units  
Cooling Capacity: 769 kW / 218 USRT

**Spain** Monument Hotel



Air Conditioning System:  
VRF 2-way ME1 series 4 systems,  
VRF 3-way 12 systems  
Indoor Units: 171 units  
Cooling Capacity:  
592 kW / 168.33 USRT

**Russia** River Park Hotel



Air Conditioning System:  
VRF 2-way ME1 series 47 systems  
Indoor Units: 96 units  
Cooling Capacity: 788 kW / 224 USRT

**Germany** The LEGOLAND Castle Hotel



Air Conditioning System:  
VRF 3-way MF2 12 systems  
Indoor Units: 144 units  
Cooling Capacity:  
592 kW / 168.33 USRT

## OFFICE

**Malaysia** Gapruna project



Air Conditioning System:  
VRF 2-way FSV ME1 series 109 systems  
Indoor Units: 537 units  
Cooling Capacity:  
5,370 kW / 1,526 USRT

**Malaysia** Plaza 33 Office Block A



Air Conditioning System:  
VRF 2-way FSV ME1 series 99 systems  
Indoor Units: 153 units  
Cooling Capacity:  
3,667 kW / 1,042 USRT

**Thailand** Areeya



Air Conditioning System:  
VRF 2-way FSV ME1 series 19 systems  
Single split system 67 systems  
Indoor Units: 85 units  
Cooling Capacity:  
1,519 kW / 432 USRT

**HongKong** King Yip Road



Air Conditioning System:  
VRF FSM LA1 series 136 systems  
Indoor Units: 294 units  
Cooling Capacity:  
2,108 kW / 599 USRT

**England** Soapworks



Air Conditioning System:  
VRF 3-way MF2 77 systems  
with ERV 167 systems

**Spain** PTA Malaga



Air Conditioning System:  
VRF 2-way ME1 series 20 systems  
Indoor Units: 74 units  
Cooling Capacity:  
908 kW / 258 USRT

**Russia** Russian Government Building



Air Conditioning System:  
VRF 2-way ME1 series 42 systems  
Indoor Units: 277 units  
Cooling Capacity:  
2,045 kW / 581 USRT

## RETAIL

**Italy** Le Centurie CENTRO COMMERCIALE



Air Conditioning System:  
VRF 3-way ME1 series 18 systems  
Indoor Units: 57 units  
Cooling Capacity:  
656 kW / 186 USRT

**India** Sai Aarav Motors, Mehsana



Air Conditioning System:  
VRF 2-way FSV ME1 series 3 systems  
Indoor Units: 19 units  
Cooling Capacity: 156 kW / 44 USRT

**Russia** Sun City Mall



Air Conditioning System:  
VRF 2-way ME1 series 47 systems,  
VRF 3-way 12 systems  
Indoor Units: 283 units  
Cooling Capacity:  
1,605 kW / 456 USRT

## SCHOOL

**United States** Shippensburg University



Air Conditioning System:  
VRF 3-Way MF1 series 55 systems  
Indoor Units: 530 units  
Cooling Capacity:  
1,498 kW / 426 USRT

## SCHOOL

**Malaysia** Xiamen University



Air Conditioning System:  
VRF FSV Systems 110 systems  
Indoor Units: 1,349 units  
Cloud adapter: CZ-CFUSCC1 17 pcs

**Russia** Technopark of Nobosibirsk Academgorodok



Air Conditioning System:  
VRF 2-way ME1 series 38 systems,  
VRF 3-way 12 systems  
Indoor Units: 234 units  
Cooling Capacity:  
1,487 kW / 422 USRT

## HOSPITAL

**Indonesia** Bekasi Hospital



Air Conditioning System:  
VRF 2-way FSV ME1 series 42 systems  
Indoor Units: 283 units  
Cooling Capacity:  
1,834 kW / 524 USRT

**Indonesia** Persada Hospital



Air Conditioning System:  
VRF 2-way FSV ME1 series 21 systems  
Indoor Units: 116 units  
Cooling Capacity:  
989 kW / 281 USRT

## RESIDENTIAL

**China** Star River Group Luxury Condominium



Air Conditioning System:  
VRF Master series 966 systems  
Indoor Units: 3,948 systems  
Cooling Capacity:  
16,737 kW / 4,755 USRT

**Singapore** Punggol Eco-Town



Air Conditioning System:  
Inverter multi-split room air conditioner  
Indoor Units:  
Wall mounted S Series (with ECOWALL)  
Control System: Panasonic HEMS

**Hong Kong** Gloucester Road Project



Air Conditioning System:  
VRF FSM LA1 series 67 systems  
Twenty series 105 systems  
Indoor Units: 255 units  
Cooling Capacity: 1,391 kW / 395 USRT

**Hong Kong** The Green Project



Air Conditioning System:  
VRF FSM LA1 series 239 systems  
Twenty series 538 systems  
Indoor Units: 999 units  
Cooling Capacity:  
6,425 kW / 1,825 USRT

**India** Royal Orchids Eco-Green Homz



Air Conditioning System:  
VRF 2-way FSV ME1 series 22 systems,  
Indoor Units: 139 units  
Cooling Capacity:  
802 kW / 228 USRT

**India** Heera Windfaire



Air Conditioning System:  
VRF 2-way FSV ME1 series 96 systems,  
VRF 3-way 12 systems  
Indoor Units: 479 units  
Cooling Capacity: 2,184kW / 620 USRT

**Panama** Mosaic Building PANAMA PACIFICO



Air Conditioning System:  
VRF 2-way FSV LE1 series 156 systems  
Indoor Units: 357 units  
Cooling Capacity: 2,338 kW / 664 USRT